

1/3" CCD COLOR
BALL CAMERA

TVC-750



The TVC-750 is a high-performance color ball camera with 1/3" CCD and fixed lens used for semi-covert or designer-type applications.

The ball camera is based on a superior design that includes line-locked synchronization with phase adjustment, thereby eliminating switch roll. The attractively designed and durable housing is weather-resistant, making the cameras ideal for outdoor as well as indoor applications at high-end commercial installations, museums and even residences. This easy-to-install high-performance ball camera is available with a 3.6mm lens.

Quality

Products

That

Make

a

Difference

FEATURES

- 1/3" interline transfer color CCD image sensor
- Resolution of 330 lines
- Line locked sync with phase adjustment
- Electronic shutter
- Easy installation
- Attractive enclosure
- Indoor or outdoor installation
- 24V ac, low power consumption
- 2-year limited warranty



TVC-750

TECHNICAL SPECIFICATIONS

ELECTRICAL

Image Sensor	1/3" interline transfer CCD
Active Pixels	512H x 492V
Image Sensor Area	4.9mm H x 3.7mm V
Resolution	330 horizontal TV lines
Minimum Scene Illumination	2.0 lux (F2.0, 50% IRE)
S/N	> 44dB
Gamma Correction	0.45
Electronic Shutter	1/60 to 1/100,000 sec
White Balance	Auto
Sync System	60 Hz line lock
Signal Format	NTSC, 525 lines, 2:1 interlace
Video Output	1.0 Vp-p, negative sync 75 Ohms (termination)
Power Requirements	24V ac \pm 10%, 60Hz \pm 1%
Power Consumption	Max. 4.5W (24V ac)

MECHANICAL

Lens Type	3.6mm, F2.0 fixed focus
Lens Mount	Miniature, fixed
Camera Mount	1/4" - 20 UNC of through hole
Dimensions	6.8L x 4.0D" (173L x 102D mm)
Weight	1.32 lbs (600g)

GENERAL

Ambient Temperature	14°F - 122°F (-10°C - 50°C)
Ambient Humidity	0% - 95% (non-condensing)

Design and specifications are subject to change without notice.

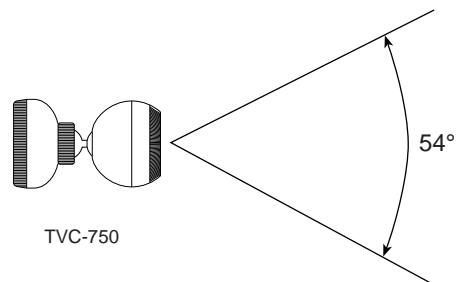
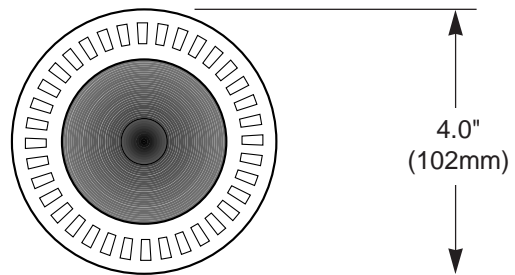
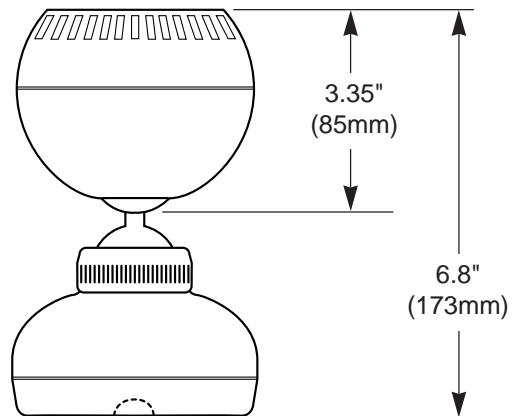

Ultrak Worldwide Support Center and Eastern Regional Office:

1301 Waters Ridge Drive
Lewisville, TX 75057
(800) 796-2288 (972) 353-6400 Fax (972) 353-6670

Ultrak Western Regional Office:

6252 West 91st Avenue
Westminster, CO 80030
(800) 846-8884 (303) 428-9480 Fax (303) 429-6609

